

### SANYO Microcontrollers Ultra-Low Power Consumption 120-pin 16-bit Flash Microcontroller Developed

Industry's lowest power consumption\*1

Ultra-low power consumption, **0.4μA** standby current, achieved!  
Making a valuable contribution to energy savings in electronic equipment  
(in the real-time clock operation mode\*2).

#### 16-bit LCD Flash Microcontroller LC88F85D0A

Sample shipping : March.2009  
Production plan : 1MPcs/M  
Sample price : @US\$8.00

We optimized the circuit design to enable lower power consumption in the real-time clock operation mode.

Using a process with minimal leakage current, a current consumption of **0.4μA (typ.)** has been achieved.  
Power consumption: **Reduced by 85% compared** to existing SANYO products.

**This translates into a dramatic increase in the battery life of electronic products and contributes to conserving the global environment.**

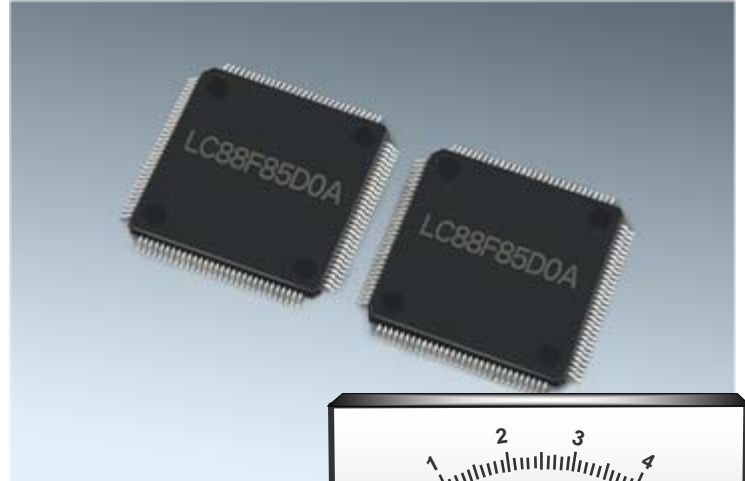

\*1 : As of January 26 2009  
In the software real-time clock operation mode  
\*2 : Standby mode of the set incorporating the device with the software real-time clock ON and the LCD display OFF

#### Low current consumption: Comparison with existing products

The ultra-low current consumption levels of our new device opens the door to impressive reductions in power consumption, conserving the global environment !

Less than **0.4μA** in real-time clock operation  
(**85% reduction compared** to existing SANYO products)

	New product	Existing products
In the real-time clock operation mode	<b>0.4 [μA]</b>	<b>3.5 [μA]</b>
Number of display dots	Up to 1536 dots	Up to 1024 dots
Software development environment	1-wire communication	-

\* : Flash products are licensed from Silicon Storage Technology, Inc., (USA) , and manufactured and sold by SANYO Semiconductor Co., Ltd.

Feature 1

**48 x 32 (1,536) dot matrix LCD displays, optimally suited to mobile devices and small electronic products, are now made possible.**



- Number of common: 32/16 software selectable
- Contrast adjustment: 16 steps, software selectable
- Dedicated LCD display RAM incorporated



Reduced current consumption

Feature 2

**Simple software development environment with 1-wire communication**

- 1-wire communication enables all the I/O pins to be used even during debugging.
- RAM referencing and changes are possible while user programs are running.
- Flash memory write function using 1-wire communication is available

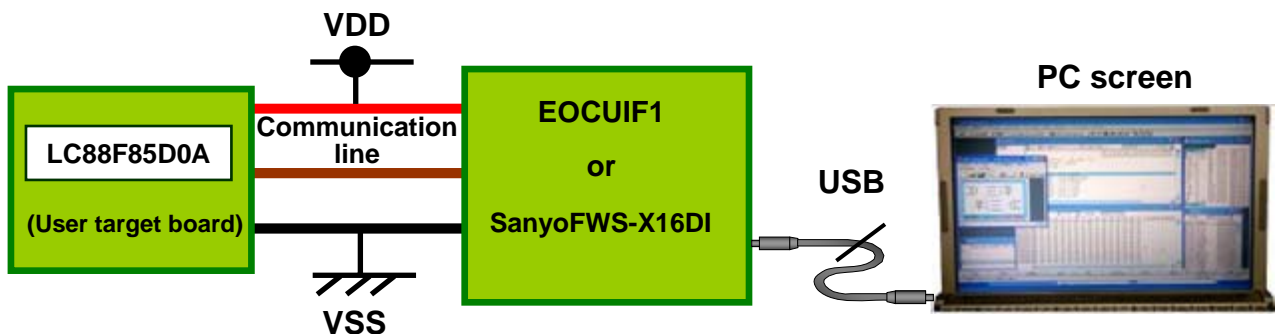

1-wire communication development environment, actual image

